

# ICOHTEC NEWSLETTER

N° 164, November 2019

[www.icohtec.org](http://www.icohtec.org)

Feb. 12, 1935.

R. J. VAN DE GRAAFF

1,991,236

ELECTROSTATIC GENERATOR

Filed Dec. 16, 1931

4 Sheets-Sheet 1

*Fig. 1.*

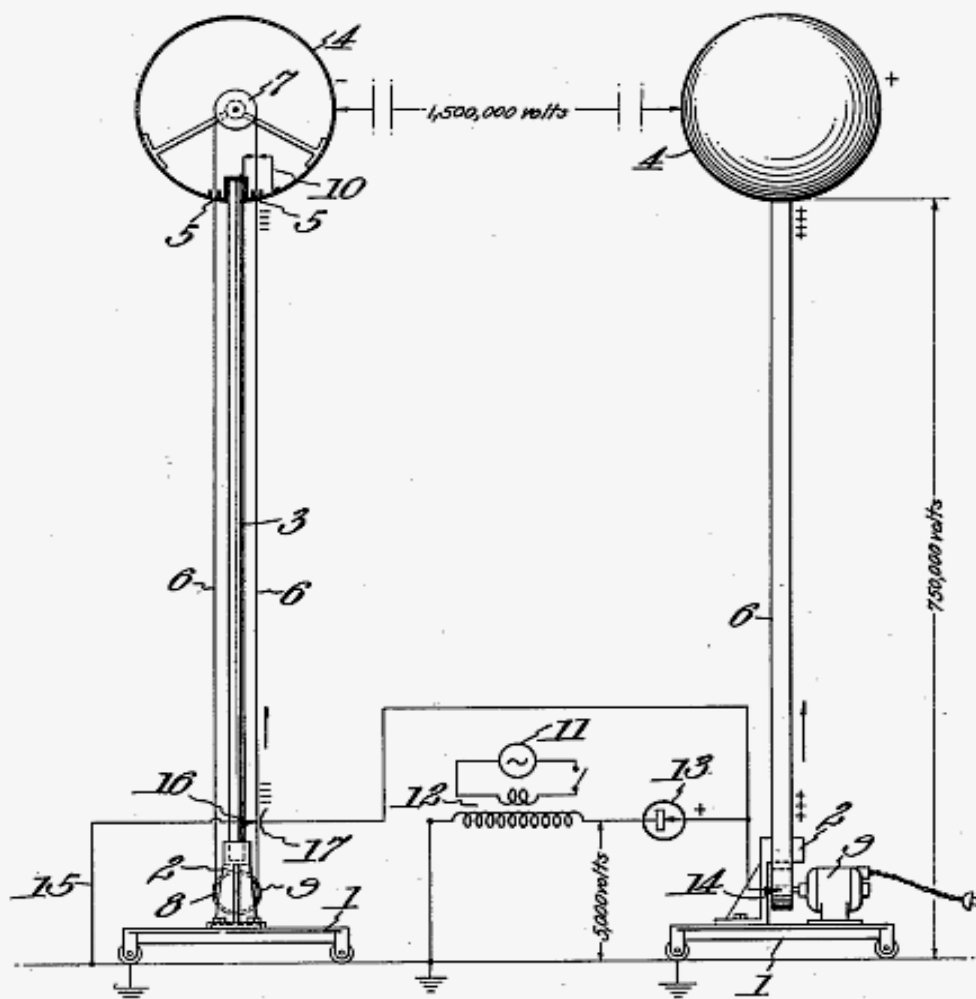

Inventor:

*Robert J. Van de Graaff,*

*By* *Byrnes, Downsend & Potter,*  
Attorneys.

The Van Der Graaf Generator' sound: <https://youtu.be/QirBEp-INss>

# Newsletter of the International Committee for the History of Technology - ICOHTEC

Editor: Francesco Gerali, The University of Oklahoma School of Library and Information Studies.  
Norman, OK, United States. Mail to [fgerali@ou.edu](mailto:fgerali@ou.edu)

I. ICOHTEC	P.2
I.1 ICOHTEC 47 <sup>TH</sup> SYMPOSIUM, EINDHOVEN 2020 - CALL FOR PAPERS	P.2
I.2 ICOHTEC 48 <sup>TH</sup> SYMPOSIUM, PRAGUE 2021 - CALL FOR PAPERS	P.5
I.3 TURRIANO ICOHTEC PRIZE - 2020 CALL FOR APPLICATIONS	P.7
I.4 MAURICE DAUMAS PRIZE - 2020 CALL FOR APPLICATIONS	P.8
II. EXHIBITS: IMAGING WOMEN IN THE SPACE AGE - EXTENDED	P.9
III. 2019 DIBNER AWARD FOR EXCELLENCE IN MUSEUM EXHIBITS	P.10
IV. LADY SCIENCE	P.11
V. PRIZES	P.12
VI. CONFERENCES, SEMINARS AND WORKSHOPS ANNOUNCEMENTS	P.12
VII. CALLS FOR MANUSCRIPTS	P.16
VIII. CALLS FOR PAPERS	P.18
IX. JOBS, POSTDOCTORAL POSITIONS, AND RESEARCH FELLOWSHIPS	P.24
X. JOIN ICOHTEC	P.31

## I. ICOHTEC

### I.1 ICOHTEC 47<sup>TH</sup> SYMPOSIUM, EINDHOVEN 2020 - CALL FOR PAPERS

# A History of Technology for an Age of Crisis

The International Committee for the History of Technology's 47<sup>th</sup> Symposium in Eindhoven, the Netherlands, 13 – 18 July 2020, Eindhoven University of Technology, TU/e

**Deadline for proposals is Sunday, 5 January 2020**

Technology and crisis are linked in multiple and paradoxical ways: although technological developments have precipitated many crises, technology has just as often been proposed as a proper way out. Resistance against new technologies (such as the 19<sup>th</sup> century Luddite movement or the 20<sup>th</sup> century anti-nuclear movement), subversive uses of mainstream technological solutions, and some instances of user-innovation and appropriation can be studied as indications of crisis as well as strategies to cope with crisis. In general, members of industrialized societies seem to have a very strong belief in technology and innovation as key to manage and solve crises: in case of the long lasting crisis of the 19<sup>th</sup> century, labeled the “Social Question”, there was demand for new technologies solving social problems as well as those of industrial health and safety. Although the expression is linked to 19<sup>th</sup> century, the Social Question is on display until today – now combined with the Environmental Crisis.

Politics mirror the paradoxical relation of technology and crisis: although democratic and authoritarian regimes, and political parties of very different stripes, might disagree fundamentally about the causes and nature of crises and the issues at stake, they have often converged in favoring technological solutions to major societal challenges. Attempts to deal with the Environmental Crisis (which is largely technology-made in the sense that anthropogenic climate change, biodiversity loss, and resource depletion followed the expansion of the human-built world) seems to follow a similar path: technological fixes are discussed, ranging from renewable energy, AI-based efficiency, sensor technologies, electric cars, smart homes, and other 'sustainable', 'responsible' or 'smart' innovations. Such approaches often sidelined non-tech solutions such as zero-growth. It remains an open question whether technology will provide solutions.

This raises the question if and how historians of technology should engage with present-day debates on the ambivalent roles of technology in today's global crisis—the so-called grand challenges to humanity, society, and the environment. The paradox of crisis and technology rises questions such as:

- In which way have crises influenced technological change, and conversely, how have technologies shaped crises?
- What's the role of technology to predict, avoid, or manage crises?
- How can we study the geography of crisis, taking into account transnational and (post)colonial relationships and global North-South interactions?
- In which way did different societies and societal groups cope with technology-related crises?
- How has the historic pursuit of innovation by technology companies and designers contributed to the creation of technological crises?
- What role(s) did protests and resistance against technology play in avoiding or managing technology-related problems or crises?

- How have media representations shaped narratives of technological crises and/or technological redemption?
- Do crises “reveal” how deeply technology is embedded in society?
- What (and whose) histories do the imaginaries and historiographies of technological crises highlight and obscure?

We invite sending in paper- and session proposals on technology & crisis for a broad range of historical periods, geographies, and crisis domains—including political conflicts, social and civil rights, colonial practices, health epidemics and health care, economic depressions, environmental disasters, and so on, along with the crises of collective identity that are often related to both technological crises and technological solutions. Contributions which examine the correlations of crisis and technology are welcome, as are case studies of specific technologically-related crises, and presentations which explore the implications and interconnections of technological crisis in media representation, art, and legislation for example. In Eindhoven, ICOHTEC will organize the usual Summer School on the same subject before the Symposium. Detailed information on the program, instructors, and travel grant in aid will be released soon. Beside contributions to the main theme of the symposium, paper and session proposals on different topics of the history of technology are welcome.

### **Proposal Guidelines**

The symposium welcomes scholarship on all periods of history and all areas of the globe, especially contributions from beyond Europe and the United States, and presentations on regions that have been less extensively covered by historians of technology. In keeping with a cherished tradition of the field, the meeting is open to scholars from all disciplines and backgrounds. The conference language is English. Although we invite to submit individual papers as well, priority will be given to proposals of whole sessions.

#### INDIVIDUAL PAPER proposals must include:

- (1) a 300-word (maximum) abstract and
- (2) a one-page (maximum) CV.

Abstracts should include the author’s name and email address, a short descriptive title, three to five key words, a concise statement of the thesis, a brief discussion of the sources, and a summary of the major conclusions. If you are submitting a paper proposal dealing with a particular subtheme in this CfP, please indicate this in your proposal. In preparing your paper, remember that presentations are not full-length articles. You will have no more than 20 minutes to speak, which is roughly equivalent to 8 double-spaced typed pages. For more suggestions about preparing your conference presentation, please consult the guidelines at the conference website <http://www.icohtec.org/w-annual-meeting/proposal-guidelines/>. Contributors are encouraged to submit full-length versions of their papers after the conference for consideration by ICOHTEC’s peer-reviewed journal *ICON*.

#### PANEL proposals must include:

- (1) an abstract of the panel (300 words maximum), listing the proposed papers and a session chairperson;
- (2) an abstract for each paper (300 words maximum);
- (3) a one-page CV (maximum) for each contributor and chairperson.

Panels should consist of three or four speakers. Several panels may be organized on one topic. We encourage creating panels which examine history of technology in different parts of the world, enabling international comparisons, and contributing to an emerging transnational historiography. Please note, the programme committee reserves the right to make adjustments to proposed panels, relocating papers to different themes and/or adding papers to panels, as required.

POSTER proposals must include:

- (1) a 300-word (maximum) abstract; and
- (2) a one-page CV.

Abstracts should include the author's name and email address, a short descriptive title, a concise statement of the thesis, a brief discussion of the sources, and a summary of the major conclusions.

The programme committee also encourages submission of ALTERNATIVE FORMATS for sessions: round tables, the presentation of an important book or film, etc. If you wish to submit a proposal for a session in an alternative format, please contact the Chair of the Program Committee, Stefan Poser, stefan.poser(at)kit.edu. Please consider joining ICOHTEC. **Members of ICOHTEC pay reduced conference fees.** Additional benefits of membership and subscription information can be found at <http://www.icohtec.org/a-homepage-section/join-or-renew-icohtec/>

### **Proposal submissions**

The final deadline for all submissions is **Sunday 5 January 2020.**

Instructions on submissions can be found on our website: <http://www.icohtec.org/>. Please submit your session, individual paper, or poster, online: <http://www.icohtec.org/w-annual-meeting/eindhoven-2020/> The submission form will guide you through the submission process. If questions arise, please consult the pdf document 'Technical instructions', which can be found on the opening page of the submission form and downloaded.

### **The Program Committee**

Stefan Poser GE (Chair) [stefan.poser@kit.edu](mailto:stefan.poser@kit.edu)

Francesco Gerali IT

Jan Hadlaw CA

Stefan Krebs LUX

Jacopo Pessina IT

Thomas Schütz GE

Kamna Tiwary IND

Erik van der Vleuten NL

Artemis Yagou GE/GR

Magdalena Zdrodowska PL

## Giants and Dwarfs in Science, Technology and Medicine

The International Committee for the History of Technology will hold its 48th symposium as part of the 26th International Congress of the History of Science and Technology in Prague, Czech Republic, 25 – 31 July 2021 (ICHST) <https://www.ichst2021.org/>

**Deadline for proposals is 10 January 2020**

The general theme of the Congress is “**Giants and Dwarfs in Science, Technology and Medicine**” and ICOHTEC encourages proposals for sessions dealing with the history of technology within this broad framework. The programme committee offers the following sub-themes for the consideration of session organizers and contributors, but welcomes proposals on a wide spectrum of topics related to the general Congress theme in the context of history of technology.

1. Gender and Technological Systems
2. Class, Poverty, and Technology
3. Technology Usage by Minorities and Small States in a Global World
4. Migration and Transportation
5. Maintaining Technological Systems, Large and Small
6. Politics, Protest, and Big Technology
7. Technological Teams
8. Global Military Technologies and Societies
9. Art and Play – Technologies and Protest
10. Environmental Change and Energy Systems
11. Assistive Technologies and (Dis)ability Studies
12. Sustainability and Economies of Scale
13. Traditional Engineering and new IT Technologies
14. Workers in Post-industrial Society
15. Medical Technologies

We urge contributors to organize a **full session** of three papers, or multiple related sessions of three papers each, with a named chair for each session. Session organizers should reflect diversity and, consistent with the diversity of this international conference ICHST has asked that there be **two organizers from different countries for each session**. Individual paper submissions may be considered if deemed appropriate, but **full sessions are strongly preferred and will be given priority**. The programme committee encourages the organizers of sessions to announce their plans to compile sessions and communicate with potential collaborators through H-NET and other networks such as social media. ICOHTEC offers to publish an organizer’s call for an ICOHTEC session on our conference page (send them directly to [s.lotysz@gmail.com](mailto:s.lotysz@gmail.com)). Calls concerning any topic of HoT are welcome. It is also possible to propose sessions unrelated to the general Congress theme. We especially encourage graduate students and early career researchers to participate in the symposium and submit their proposals. Limited travel grants will be available; for further information go to: <http://www.icohtec.org>.

**SESSION** proposals must include: (1) an abstract of the session (350 words maximum), listing the proposed papers (see individual paper proposal guidelines below), the **two organizers from different countries** and the chairperson; (2) abstracts for each paper (250 words maximum); (3) a **one-page CV (maximum)** for each contributor and chairperson. Sessions should consist of at least one set of presentations (90 minutes time slot) and they may include three or four papers in each, which might extend to a series of successive sections over more than one day. Each individual section should have a chairperson. Proposing a commentator – instead of the fourth presenter – is also possible. The programme committee reserves the right to relocate papers to different themes and add papers to sessions. We also encourage proposing roundtables and other “new” as well as innovative, experimental session formats. Whatever the session format will be, organizers and chairs are expected to reserve enough time for general discussion between the presenters and audience. Individual paper abstracts should include the author’s name and email address, a short informative title of the paper, a concise statement of the thesis, a brief discussion of the sources, and a summary of expected conclusions. In preparing your paper, remember that presentations are not full-length articles. You will have no more than 15-20 minutes speaking time, which is roughly equivalent to 6-8 double-spaced typed pages. Contributors are encouraged to submit full-length versions of their papers after the congress for consideration by ICOHTEC’s journal *ICON*. If you are submitting an independent paper proposal dealing with a particular sub-theme, please indicate this in your proposal.

#### **PROPOSAL SUBMISSIONS**

Submit all session and individual paper proposals to: [www.prague2021.icohtec.org](http://www.prague2021.icohtec.org).

The final deadline for all submissions is **Friday 10 January 2020**. Please check updated instructions on submissions at our website: <http://www.icohtec.org/>. Please pay close attention to the instructions, particularly the word length of submitted documents.

**Please note that this date is only 5 days later than the submission date for the 2020 ICOHTEC Eindhoven proposals.** Because of the complex nature of organizing so large a meeting, this call for papers has an unusually early deadline.

#### **PROGRAMME COMMITTEE:**

Susan Schmidt Horning, Chair (USA)

Florian Bettel (Austria)

Roberto Cantoni (Spain)

Jiri Janac (Czech Republic)

Fanxiang Min (China)

Peeter Mürsepp (Estonia)

Jan Musekamp (USA)

Jaroslav Svelach (Czech Republic)

Ewelina Twardoch (Poland)

Ruth Schwartz Cowan (USA)

### I.3 TURRIANO ICOHTEC PRIZE - 2020 CALL FOR APPLICATIONS

The Turriano ICOHTEC Prize is an Early Career Prize for Books on the history of technology, sponsored by the [Juanelo Turriano Foundation](#) and consists of 2,500 Euro. The prize-winning book will be presented and discussed at a special session of the next ICOHTEC symposium, in Eindhoven, The Netherlands, from 13-18 July 2020. An additional 500 Euro is available to the winner in support of travelling to the conference to receive the prize. ICOHTEC, the International Committee for the History of Technology, is interested in the history of technology, focusing on technological development as well as its relationship to science, society, economy, culture and the environment. The history of technology covers all periods of human history and all populated areas. There is no limitation as to theoretical or methodological approaches. Eligible for the prize are original book-length works in any of the official ICOHTEC languages (English, French, German, Russian or Spanish) in the history of technology: published or unpublished Ph.D. dissertations or other monographs written by scholars in the early parts of their career. Articles and edited anthologies are not eligible. If the work is a Ph.D. thesis, it should have been accepted by your university in 2018 or 2019; if it is a published work, the year of publication should be 2018 or 2019. For the ICOHTEC Prize 2020, please send an electronic copy (PDF or Word) of the work you wish to be considered for the prize to each of the four Prize Committee members. (Note: Hard copies are only accepted for published works not available electronically.)

**Your submission must be emailed no later than Friday, 1 February 2020.** Please also include an abstract of no more than a half-page in length. If your book is in Spanish or Russian, please also supply a summary in English, French or German of about 4,500 words. In that case, the prize committee will find additional members, who are familiar with the language in which your book is written. The submission should be accompanied by a CV (indicating also the date of birth) and, if applicable, a list of publications. Applicants are free to add references or reviews of the work submitted. Any materials sent to the prize committee will not be returned. Send a complete application by email to each of the following **Prize Committee members**:

**Prof. Ernst Homburg** , Prize Committee Chairperson

Maastricht University, Department of History  
Faculty of Arts and Social Sciences, P.O. Box 616  
6200 MD Maastricht, The Netherlands  
[e.homburg@maastrichtuniversity.nl](mailto:e.homburg@maastrichtuniversity.nl)

**Dr. Irina Gouzevitch**

Centre Maurice Halbwachs, ESHES-CRNS-ENS  
École Normale Supérieure, 48, boulevard Jourdan  
75014 Paris, France  
[irina.gouzevitch@ens.fr](mailto:irina.gouzevitch@ens.fr)

**Prof. Per Lundin**

Chalmers University of Technology, Div. of Science, Technology and Society  
Dept. of Technology Management and Economics, SE - 412 96 Gothenburg, Sweden  
[per.lundin@chalmers.se](mailto:per.lundin@chalmers.se)



**Dr. Darina Martykánová**

Universidad Autónoma de Madrid, Departamento de Historia Contemporánea  
Facultad de Filosofía y Letras, Campus de Cantoblanco  
28049 – Madrid, Spain  
[darina.martykanova@uam.es](mailto:darina.martykanova@uam.es)

**Dr. Klaus Staubermann**

ICOM Germany  
In der Halde 1  
14159 Berlin, Germany  
[staubermann@icom-deutschland.de](mailto:staubermann@icom-deutschland.de)

**I.4 MAURICE DAUMAS PRIZE - 2020 CALL FOR APPLICATIONS**

The Maurice Daumas Prize for papers on the history of technology is sponsored by the [Université de Technologie de Belfort-Montbéliard](#) (UTBM), France, and consists of 500 Euro. Each year the prize-winning article is presented and discussed at a special session of the ICOHTEC symposium immediately following the award. An additional 300 Euro is available to the winner in support of traveling to the conference to receive the prize. The prize aims to encourage innovative scholarship in the history of technology. ICOHTEC is interested in the history of technological development as well as its relationship to science, society, economy, culture and the environment. There is no limitation as to theoretical or methodological approaches. The prize will be awarded to the author of the best article submitted which deals with the history of technology in any period of the past or in any part of the world and which was published in a journal or edited volume in last two consequent years. Eligible for the prize are original articles published in (or later translated into) any of the official ICOHTEC languages (English, French, German, Russian or Spanish). Submissions are welcomed from scholars of any country who are currently in graduate school or have received their doctorate within the last seven years.

**Call for submissions 2020**

ICOHTEC, welcomes submissions for the *Maurice Daumas Prize* for 2020. Eligible for the prize are original articles published in 2018 or 2019. Please send your submission and a brief (not to exceed one-page) cv to each of the six Prize Committee members **no later than 15 January 2020. Electronic submissions are preferred.** The winner will be contacted in late April 2020. The prize will be awarded at our 47<sup>th</sup> Symposium, to be held in Eindhoven, The Netherlands, in summer 2020 (13-17 July). The winner will receive a cash prize of Euro 500 as well as a travel grant up to 300 Euro (if needed) to attend the ICOHTEC Symposium, which will feature a special panel organized around the winning article.

**PRIZE COMMITTEE**

**Maria Elvira Callapez**, Pl. Dr., [Prize Committee Chairperson],  
CIUHCT, Faculdade de Ciências, Universidade de Lisboa, **Portugal**  
E-mail: [mariaelviraallapez@gmail.com](mailto:mariaelviraallapez@gmail.com)

**Antoni Roca-Rosell, Dr.**

[Universitat Politècnica de Catalunya](#)

Barcelona, Catalunya, **Spain**

E-mail: [antoni.roca-rosell@upc.edu](mailto:antoni.roca-rosell@upc.edu)

**Eike-Christian Heine, Dr.**

Technische Universität Braunschweig, **Germany**

E-mail: [eikechristian.heine@gmail.com](mailto:eikechristian.heine@gmail.com)

**Laurent Heyberger, Dr.**

Université de technologie de Belfort-Montbéliard (UTBM), **France**

E-mail: [laurent.heyberger@utbm.fr](mailto:laurent.heyberger@utbm.fr)

**Liliia Zemnukhova, PhD**

Sociological Institute of the Russian Academy of Sciences (SI RAN), St. Petersburg,

**Russian Federation**

E-mail: [l.zemnukhova@gmail.com](mailto:l.zemnukhova@gmail.com)

**Lino Camprubí, Dr.**

Universidad de Sevilla, Facultad de Filosofía, **Spain**

E-mail: [lcamprubi@us.es](mailto:lcamprubi@us.es)

## **II. EXHIBITS: IMAGING WOMEN IN THE SPACE AGE: EXTENDED**

### **Imaging Women in the Space Age.**

#### **New Art Exhibition on View at the New York Hall of Science**

**July 13 – November 3, 2019**

Exhibit Curator Julie Wosk, Professor Emerita, State University of New York,

Maritime College, Queens, NY. [jwosk@sunymaritime.edu](mailto:jwosk@sunymaritime.edu)

<https://nysci.org/imaging-women-in-the-space-age/>

Dr. Julie Wosk, Professor Emerita at SUNY Maritime College in Throggs Neck, NY reports that her exhibit “Imaging Women in the Space Age” at the New York Hall of Science in Queens, NY has now been extended until **March 29, 2020**. After that, it will be available to travel. She has also written an essay on this topic which will appear in an upcoming book on the cultural and political impact of the Apollo 11 lunar landing. For further information about the exhibit contact [jwosk@sunymaritime.edu](mailto:jwosk@sunymaritime.edu)

July 2019 marks the 50th anniversary of the Apollo 11 lunar landing, and to help celebrate, the New York Hall of Science (NYSCI) is presenting a new exhibition *Imaging Women in the Space Age*, curated by Dr. Julie Wosk, Professor Emerita at SUNY Maritime College and author of *Women and the Machine*. The exhibit runs from July 13 – November 3, 2019. The exhibition showcases the achievements of America’s pioneering female astronauts and highlights the fascination with space women in movies, television, advertising, fashion design and today’s toys. From the earliest moon goddesses to today’s galactic fashions, visions of females in space have sparked the creative imagination. On display in the museum’s gallery are vintage and current images of female space

travelers in television shows like *Lost in Space* and *Star Trek*, photographs of space-inspired fashions including Pucci's designs for Braniff Airlines flight attendants and Chanel's 2017 futuristic dresses, and screenshots from films like *barbarella*, which starred Jane Fonda and *Gravity*, which starred Sandra Bullock. The exhibition reminds us of the groundbreaking achievements of pioneering astronauts with photographs of Sally Ride, America's first woman in space, Mae Jemison, America's first African-American female astronaut, and Ellen Ochoa, America's first Hispanic woman to go into space. Also on view are photographs of astronaut Dr. Ellen K. Baker, who grew up in New York City and is the daughter of former Queens Borough President Claire Shulman. The exhibition also reflects a world where important changes are underway as more and more women are participating in NASA's space program as astronauts and as aeronautical engineers. It reveals innovative new developments in space suits specifically designed for women. *Imaging Women in the Space Age* is part of the museum's Space Out Summer, a season filled with flight and space-themed exhibits, workshops, demonstrations, installations and a new film, all to celebrate the 50th anniversary of the Apollo 11 mission.

**Further Contact:** Mary Record, New York Hall of Science, [mrecord@nysci.org](mailto:mrecord@nysci.org), 718-595-9123

### III. 2019 DIBNER AWARD FOR EXCELLENCE IN MUSEUM EXHIBITS

The exhibition *Plasticity - a History of Plastics in Portugal* (*Plasticidade - uma História dos Plásticos em Portugal*) - an output of the Project "The Triumph of Bakelite- Contributions for a History of Plastics in Portugal" - in the Leiria Museum, Portugal, **awarded the 2019 Dibner Award for Excellence in Museum Exhibits.** (<https://www.historyoftechnology.org/2019/10/20/society-for-the-history-of-technology-award-and-fellowship-winners-2019/>)

The Dibner Award for Excellence in Museum Exhibits was established in 1985, through the generosity of Bern Dibner, to recognize excellence in museums and museum exhibits that interpret the history of technology, industry, and engineering to the general public. (<https://www.historyoftechnology.org/about-us/awards-prizes-and-grants/the-dibner-award/>)

The 2019 Dibner Award Committee consisted of Liz Bruton, Robert Bud, Arthur Daemmrich, Benjamin Gross (chair), Valerie Neal, and Jahnvi Phalkey.

Maria Elvira Callapez

Coordinator of the Project "The Triumph of Bakelite. Contributions for a History of Plastics in Portugal"



**Maria Elvira Callapez**  
Investigadora Principal | *Principal Investigator*

Centro Interuniversitário de História das Ciências e da Tecnologia da Faculdade de Ciências,  
Universidade de Lisboa (CIUHCT-FCUL)  
Tel.: (+351) 21 750 0728 (ext.: 24 318)  
Telem.: | Mobile: (+351) 96 799 1343

 O Triunfo da Baquelite  <http://plasticos.ciuhct.org/>  



# LADY SCIENCE

## *Magazine & Podcast*

### CALL FOR WRITERS

Lady Science is an online magazine and podcast about women and gender in the history of science. We publish a wide variety of writing on the constellation of women, gender, and the history and future of science, technology and medicine. Founded by two trained historians of science, the mission of Lady Science is to publish engaging, critical writing about the past, present, and future of women in science.

Lady Science offers an excellent paid opportunity for scholars to publish their work on the web for a broad audience. Our collaborative editing process ensures that writers' work retains its scholarly rigor while also being accessible to non-specialists. If you are interested in contributing or have questions about the process, please check out our pitch guide or email [anna@ladyscience.com](mailto:anna@ladyscience.com).

[ladyscience.com/pitch](http://ladyscience.com/pitch)

**LADY SCIENCE  
FALL FUNDRAISER  
5K FOR 5 YEARS**

This fall, we're celebrating our 5th birthday with a special fundraising event October 7-14. Lady Science is entirely donor-supported. This fundraising drive helps us sustain our recently raised rates for writers, pay our team of editors, and plan for future projects. We're raising \$5000 for 5 years of Lady Science! [ladyscience.com/donate](http://ladyscience.com/donate)

## V. PRIZES

*History of the Human Sciences* – the international journal of peer-reviewed research, which provides the leading forum for work in the social sciences, humanities, human psychology and biology that reflexively examines its own historical origins and interdisciplinary influences – is delighted to announce its new annual prize for early career scholars. The intention of the award is to recognise a researcher whose work best represents the [journal's aim](#) to critically examine traditional assumptions and preoccupations about human beings, their societies and their histories in light of developments that cut across disciplinary boundaries. In the pursuit of these goals, *History of the Human Sciences* publishes traditional humanistic studies as well work in the social sciences, including the fields of sociology, psychology, political science, the history and philosophy of science, anthropology, classical studies, and literary theory. Scholars working in any of these fields are encouraged to apply.

Scholars of any nationality who have either not yet been awarded a PhD or are no more than five years from its award are welcome to submit entries. The judging panel will use the definition of “active years”, with time away from academia for parental leave, health problems, or other relevant reasons not counting towards the definition of eligibility. The winner of the prize will be awarded £250 and have their essay published in *History of the Human Sciences*.

Scholars who wish to be considered for the award are asked to submit an up-to-date CV (a maximum of two pages in length and including a statement that confirms eligibility for the award) and an essay, based on original research, that is a maximum of 12,000 words long (including footnotes and references) to [hhs@histhum.com](mailto:hhs@histhum.com) by 31<sup>st</sup> January 2020. For more details about the award, including submission guidelines, please see the full call for entries on [History of the Human Science's website](#).

### **García-Diego International Prize**

The Fundación Juanelo Turriano announces the 10th edition of its García-Diego International Prize, worth 12,000 euros, for research in any of the branches of the history of technology. The prize is open to any individual or group submitting an original, unpublished paper in Spanish. The deadline for submissions is 20 January 2020. [See rules \(In Spanish\)](#)

## VI. CONFERENCES, SEMINARS AND WORKSHOPS ANNOUNCEMENTS

### **Contested Data: What Happens When the Givens Aren't Taken**

CFP @ <https://datasociety.net/blog/2019/10/15/call-for-participation-contested-data-what-happens-when-the-givens-arent-taken/>

Deadline for submitting an application to share a paper or participate in workshop:

**25 November 2019**

The word “data” derives from the Latin for the givens. And though we often think about data as something to be gathered, hoarded, culled, or stripped, the reason we want it is so that it can be our givens. Data provide the basis for our analyses, valuations, decisions, or arguments. Today, data seem ever more important. Many private and public actors push for data-driven medicine or data-

driven policymaking, with a trajectory toward data-driven everything. Data must train the machine learning systems and AIs that hire and fire, parole and police, price and predict. What if people won't accept the givens? How and why do people refuse to accept data, and the infrastructures that provide data, as valid for future action? What are the larger social, political, or economic consequences of such a refusal? Much important work has already been done to investigate the knowledge practices that legitimate data, a field that has grown out of earlier studies by historians, sociologists, anthropologists, statisticians, and philosophers into practices of quantification. We are learning more and more about why people trust in numbers and in data, to extend Ted Porter's phrase. This workshop seeks papers that come at the question of legitimation from the other direction: why don't people trust in data, especially data that once was deemed trustworthy? Inspired by work on "agnotology" and on knowledge practices that produce doubt, we seek participants prepared to think beyond data mining to the process by which data is undermined. The purpose of this workshop is to bring together researchers who are examining these issues from different disciplinary and analytic perspectives. Relevant topics for this workshop might include:

- ✓ When in the past have state-produced data sets (census, official surveys, etc.) or index numbers (cost-of-living, GDP, unemployment, etc.) fallen out of use or been challenged to the point that they could no longer serve their purpose? How do alternatives to official sources of data arise?
- ✓ What practices have state, corporate, or civil society actors employed to generate doubt in a data's accuracy or utility?
- ✓ What roles have scientists or other technically sophisticated actors played in debates and controversies surrounding the legitimacy of data?
- ✓ How has the larger public engaged in debates about data and data infrastructures?

### **Third Workshop on Scientific Archives / European XFEL, Hamburg, DE / 30 June-1 July 2020**

Proposals are now being accepted for the Third Workshop on Scientific Archives,  
([https://www.xfel.eu/index\\_eng.html](https://www.xfel.eu/index_eng.html))

Proposed topics include (but are not limited to):

- ✦ Collaborating with scientists to capture contemporary scientific material
- ✦ Using scientific archives for outreach and education
- ✦ Using and re-using archival resources in current science
- ✦ Enabling access to scientific records
- ✦ Describing technical and scientific archives
- ✦ Managing and archiving research data
- ✦ Exploring the role of archives and records in open science
- ✦ Capturing diversity in institutional archives
- ✦ Scientific archives in a "post-truth" world
- ✦ Diversity and inclusion in STEM // Diversity and inclusion in archives

Papers are to be 20 minutes. Please submit a 400-word abstract using the following form by **Friday 31 January 2020**: <http://tiny.cc/e888cz>

More information can be found at: <https://www.embl.de/aboutus/archive/working-with-scientific-archives/workshop/>. Organized by the Committee on the Archives of Science and Technology (<https://www.ica.org/en/committees>) of the International Council on Archives, Section on University and Research Institution Archives (<https://www.ica.org/en/suv>)

## **Royal College of Nursing, 20 Cavendish Square, London W1G 0RN**

Join us for the launch of a new exhibition celebrating 100 years of nursing registration. Find out about the fiery characters who fought for nursing registration, view original nursing registers from the General Nursing Council (now Nursing and Midwifery Council) and trim your own hat to emulate a matron from 1919. Talks and displays will explore the different histories of health and medical Royal Colleges, from midwifery to physiotherapy; anaesthesia to optometry.

Short Talks from 6pm

- ♥ A century of nurse registration in the UK Dr Alison O'Donnell and Dr Moyra Journeaux. Alison trained as a registered general nurse. She has an honours degree in education, a Masters in Nursing and completed her PhD in 2010 at the University of Dundee. She is currently Chair of the RCN History of Nursing Forum.
- ♥ Midwifery in twentieth century Britain: from regulation to reinvention? Dr Tania McIntosh, Principal Lecturer in Midwifery at the University of Brighton. Tania is dual qualified as an historian and a midwife and has researched and written extensively on the history of midwifery and women's health.
- ♥ 'Making Massage a Safe, Clean and Honourable Profession for British Women': from Special Nursing to Physiotherapy in the early Twentieth Century. Dr Kay Nias, Medicine Galleries Research Fellow, Science Museum, London. Kay is a historian whose previous research has looked extensively at the history and material culture of physiotherapy, massage and mechanotherapy.

Displays and Activities (drop-in, all evening)

- ♣ View original nursing registers with the Nursing and Midwifery Council
- ♣ Trim your own hat with the Royal College of Nursing
- ♣ Association of Anaesthetists
- ♣ The College of Optometrists
- ♣ Bethlem Museum of the Mind
- ♣ Florence Nightingale Museum
- ♣ Royal Pharmaceutical Society
- ♣ Royal British Nursing Association collection from Kings College Archives

The exhibition runs from 17 October until 20 March 2020, celebrating 100 years of nursing registration in the UK, passed on 23 December 1919. For the full exhibition and event programme visit [www.rcn.org.uk/whatson](http://www.rcn.org.uk/whatson). Contact Info: Sarah Chaney, Royal College of Nursing Library and Archive, [rcn.library@rcn.org.uk](mailto:rcn.library@rcn.org.uk), <https://www.rcn.org.uk/whatson>

## **Collecting and Collections: Lives and Digital Afterlives**

Workshop III of the international research project, *Collective Wisdom: Collecting in the early modern Academy*, will take place November 14-15, 2019 at the Royal Society in London. This workshop, *Collecting and Collections: Lives and Digital Afterlives*, concerns the afterlives, use and reconstruction of early modern collections and is designed to benefit scholars interested in digital humanities. We will explore digital approaches to survey collections over time, assisted by the Royal Society-Google Cultural Institute partnership. How can we data-mine and use tools to integrate extant databases? How did the norms of early modern academies of scientific journal publication, priority of discovery and 'matters of fact' shape the organisation of knowledge? How do we consider those early modern models in digital reconstructions of early collecting?

Speakers include: Min Chen (Oxford), Mary-Ann Constantine (Wales), Natasha David (Google), Michelle DiMeo (Hagley), Louisianne Ferlier (The Royal Society), Rainer Godel (Leopoldina), Rob Iliffe (Oxford), Neil Johnston (TNA), Suhair Khan (Google), Nigel Leask (Glasgow), Miranda Lewis (Oxford), Alice Marples (Oxford), Alessio Mattana (Turin), Brent Nelson (Saskatchewan), Julianne Nyhan (UCL), Torsten Roeder (Leopoldina), Anna Marie Roos (Lincoln), Giacomo Savani (University College Dublin), Cornelis Schilt (Oxford), Tom Scott (Wellcome), Aron Sterk (Lincoln), Matthew Symonds (CELL, UCL). For The Royal Society, including directions to the venue, please access the website [here](#). [Register here](#). The conference programme is available [here](#). Paper [abstracts](#) are also available.

*Collective Wisdom* is funded by a networking grant award from the Arts and Humanities Research Council (AHRC). Our project partners include the Leopoldina, The Royal Society, The Society of Antiquaries of London, the Francke Foundation, The University of Lincoln and the University of Oregon.

### **Manchester CHSTM Research Seminars, 2019–20**

This is to present the speakers for the upcoming seminar series at the Centre for the History of Science, Technology, and Medicine (CHSTM), University of Manchester. Please find the programme for the 2019–20 academic year below. CHSTM seminars will be held fortnightly on **Tuesdays at 4pm** in **2.57 Simon Building**, with tea and biscuits from 3.30 pm – unless otherwise indicated. All are welcome! Please pass this on to interested colleagues/students. If you have any questions, please direct them to myself, Tom Quick ([thomas.quick@manchester.ac.uk](mailto:thomas.quick@manchester.ac.uk)) or Pratik Chakrabarti ([Pratik.chakrabarti@manchester.ac.uk](mailto:Pratik.chakrabarti@manchester.ac.uk)).

#### **Calendar of the Seminars**

Tuesdays, 4pm, Simon Building, room 2.57, unless otherwise indicated.

19 November, **Chris Manias** (King's College London). *Beasts from the earth: Reconstructing fossil mammals in the nineteenth century*

3 December, **Richard Staley** (University of Cambridge). *The undead in climate history: On the birth, life and uncertain death of the Medieval Warm Period*

28 January, **Vanessa Heggie** (University of Birmingham). *Higher and colder: A history of extreme physiology and exploration*

11 February – **7 pm, venue TBC** – Joint event with the Manchester Museum. **Angela Saini** (writer & journalist). *The return of race science*

25 February, **Beatriz Pichel** (De Montford University). *Photography and the making of modern medicine in France, 1860–1914*

10 March, **Laura Tisdall** (Queen Mary's, University of London). *'Just a stage I'm going through': Lesbian and gay adolescents, developmental psychology, and psychoanalysis in Britain, c. 1950–1990*

24 March, **Caitjan Gainty** (King's College, London). *Healthy skepticism*

21 April, **Sarah Marks** (Birkbeck, University of London). *'Brainwashing for benevolent purposes?' Historical reflections on behavioural therapy from the Cold War to CBT*



5 May, **Cornelius Borck** (University of Lübeck). *Changing approaches to visualization in brain research: A case study based on the Max-Planck Society*

## VII. CALL FOR MANUSCRIPTS

### Call for thematic issue: HoST – Journal of History of Science and Technology (2021)

HoST- Journal of History of Science and Technology is an open access, on-line peer-reviewed international journal devoted to the History of Science and Technology, published in English by a group of Portuguese research institutions and De Gruyter/Sciendo (<https://content.sciendo.com/view/journals/host/host-overview.xml>[https://urldefense.proofpoint.com/v2/url?u=https-3A\\_\\_content.sciendo.com\\_view\\_journals\\_host\\_host-2Doverview.xml&d=DwMFaQ&c=qKdtBuuu6dQK9MsRUVJ2DPXW6oayO8fu4TfEHS8sGNk&r=o6t8\\_z4yokv9K\\_SPoVvDEQ&m=k1BMYtQEuHECdHj3sksYIOYseOBL7MtFyblPmQ-SgWc&s=b51FewxO8G8YhdCGU\\_ksyj6SDlLeIdljc\\_9gcHHHilU&e=>](https://urldefense.proofpoint.com/v2/url?u=https-3A__content.sciendo.com_view_journals_host_host-2Doverview.xml&d=DwMFaQ&c=qKdtBuuu6dQK9MsRUVJ2DPXW6oayO8fu4TfEHS8sGNk&r=o6t8_z4yokv9K_SPoVvDEQ&m=k1BMYtQEuHECdHj3sksYIOYseOBL7MtFyblPmQ-SgWc&s=b51FewxO8G8YhdCGU_ksyj6SDlLeIdljc_9gcHHHilU&e=>)).

HoST encourages submissions of original historical research exploring the cultural, social and political dimensions of science, technology, and medicine (STM), both from a local and a global perspective. Past thematic issues have dealt with topics as diverse as circulation, communication of science and the relation between science and politics. Future issues might deal with both established and emerging areas of scholarship. The editors of HoST are looking for proposals for two thematic issues to be published in 2021 (HoST volume 15, issues 1 and 2). Each thematic issue should be prepared by a guest editor and include four research papers.

Proposals should include the following items:

1. An abstract describing the topic for the thematic issue and its significance (500 words);
2. A list of the contributors along with the titles and abstracts (300 words) of the four research papers;
3. Brief CVs (300 words) of the guest editor(s) and authors;

The guest editor(s) and the contributors must be prepared to meet the HoST publication schedule:

- ◆ Abstract and titles submission: **29 November, 2019**
- ◆ Submission of complete research papers: 29 May, 2020 (Issue 1) & 30 November, 2020 (Issue 2)
- ◆ Publication: June, 2021 (Issue 1) & December, 2021 (Issue 2)

Proposals will be subject to approval by the Editorial Board and the outcome will be known to the authors by December 2019. Submissions should be sent as an e-mail attachment (preferably in one single .doc, .docx, .rtf or .odt file), to the editor:

[chiefeditor@johost.eu](mailto:chiefeditor@johost.eu)<<mailto:chiefeditor@johost.eu>>

### Techniques & Culture

Call for papers for a special issue of the journal *Techniques&Culture* (to be published in Autumn 2020). *Techniques&Culture* is the reference French academic journal on technical cultures studies.

Following Jules Verne's invitation to consider remote and mysterious worlds, this issue of *Techniques&culture* focuses on the modes of exploration and habitation of universes conceived as hostile which yet stir curiosity and inventiveness. It invites us to think about the relations, mediated by techniques, that human beings maintain with noxious and even fatal environments.

Full call: <https://tc.hypotheses.org/3187>

Journal website: <https://journals.openedition.org/tc/>

Authors shall contact the coordinators of the issue, Stéphane Rennesson and Annabel Vallard, through the journal's editorial secretariat ([techniques-et-culture@ehess.fr](mailto:techniques-et-culture@ehess.fr)) to submit their project (title and abstract, iconographical project) with their name, contact details, institutional affiliation before **8 November 2019**. A meeting of the selected contributors is scheduled to take place in Marseille in January 2020. The proposal and the full text can be sent in French or English; the paper volume will be published in French, but online articles can be published in English.

***Inquiry. An Interdisciplinary Journal of Philosophy***  
**Special Issue: "Foundational Issues in Conceptual Engineering"**

Guest Editors: Manuel Gustavo Isaac (University of Barcelona) & Steffen Koch (Ruhr University Bochum). Invited Contributors: Catarina Dutilh Novaes (Vrije Universiteit Amsterdam), Édouard Machery (University of Pittsburgh), Amie Thomasson (Dartmouth College). This special issue (S.I.) is dedicated to one of contemporary's hottest topics in metaphilosophy — conceptual engineering.

Conceptual engineering is a method which aims at improving, rather than just describing, the representational tools we use in theoretical or practical contexts. More specifically, the S.I. aims to foster discussions about the theoretical foundations of conceptual engineering. What kind of objects does conceptual engineering operate on? What does it mean to 'engineer' them? And is the popular metaphor of 'engineering' concepts even appropriate? Naturally, how one answers these questions depends on one's prior theoretical commitments. The S.I. thus provides a platform for explicating crucial foundational issues in conceptual engineering. The topic of the special issue is how the method of conceptual engineering should generally be construed; in particular, we are less interested in specific suggestions for how to ameliorate this or that concept. Viable topics thus include, among others: What is the relevance of metasemantic theorizing to conceptual engineering? How does conceptual engineering look like from an internalist/externalist perspective? Does conceptual engineering operate on an individual or a communal level? How are the two connected? Does conceptual engineering operate on mental or linguistic objects? Again, how are the two connected? How should we construe the goals of conceptual engineers? What is a good method to achieve these goals? How does conceptual engineering relate to other philosophical methods? Is conceptual engineering even feasible? Papers should be prepared for anonymous review, no longer than 8,000 words, and submitted via <https://mc.manuscriptcentral.com/inquiry>. **The deadline is January 31, 2020.** For further information, please contact: Manuel Gustavo Isaac, [isaac.manuelgustavo@gmail.com](mailto:isaac.manuelgustavo@gmail.com) and Steffen Koch, [steffen.koch@rub.de](mailto:steffen.koch@rub.de).

**Vision Loss through Many Lenses: Insights from Myth, Media, Music, Medicine & More**

While vision loss directly concerns medical and mental health professions, this theme also attracts the attention of artists and scholars from many disciplines. This collection falls under the rubric of "medical humanities" and includes essays on vision loss or blindness in visual arts, literature, music, comics, film, myth, history, religion, philosophy, sociology and more—but it does not include medical

or mental health issues per se. Some topics are already accounted for but open topics include memoirs by persons who lost their vision; masculinity in blind samurai warrior series; blindness as a metaphor for color-blindness in Civil Rights era films; music by and about blind persons; why groups such as Blind Boys of Alabama proliferated in Southern U.S.A.; disability debates invoked by Oliver Sack's *Island of the Colorblind*; dance by or about persons w/ visual loss; portrayals of vision-impaired females in film; poetry by or about vision-impaired persons; Catholic/Protestant/Hindu/Muslim/Jewish attitudes toward vision loss; healing shrines and patron saints and miracle cures for vision loss; East Asian attitudes toward vision loss; philosophical debates about blindness and cognition; etc. We are open to other innovation ideas. If you are uncertain if your topic is still available, pl send a short 1-2 sentence query plus a short bio. Otherwise, pl send a short precis of 200-400 words along with a short bio &/or resume. Abstracts due 12-15-19. Papers of 3,000-4,000 words (w/ 5-15 citations) in University Chicago style due June 1, 2020 (first draft). Final drafts due August 30, 2020. Remuneration includes 1 book/essay. This essay collection is already in contract with a respected academic publisher. Contact Info: [drsharonpackermd@gmail.com](mailto:drsharonpackermd@gmail.com), add VISION LOSS through MANY LENSES in subject.

## VIII. CALLS FOR PAPERS

### 16th Annual Symposium of the Social History of Military Technology Prague, Czech Republic, 25–31 July 2021

We seek proposals for papers to be presented in the 16th Annual Symposium of the Social History of Military Technology (16SSHMT), scheduled as part of the program for the International Committee for the History of Technology (ICOHTEC), meeting as part of the International Congress of the History of Science, Technology, and Medicine (ICHSTM), Prague, Czech Republic, 25–31 July 2021. All proposals must be entered by 10 January. **Please note that this date is only 5 days later than the submission date for Eindhoven proposals.** Because of the complex nature of organizing so large a meeting, this call for papers has an unusually early deadline.

**Do not submit your paper proposal to ICOHTEC.** Bart Hacker (USA) and Ciro Paoletti (Italy) are organizing the symposium. Send your proposal directly to Bart at: [hackerb@si.edu](mailto:hackerb@si.edu), or [barthacker60@gmail.com](mailto:barthacker60@gmail.com), or to Ciro at: [ciro.paoletti.637@istruzione.it](mailto:ciro.paoletti.637@istruzione.it), no later than **8 January 2019, but earlier is better.** We will assemble and submit the complete symposium. Please distribute this CFP to anyone you believe may be interested and qualified.

ICHSTM has selected the general theme of ***Giants and Dwarfs in Science, Technology and Medicine***. In submitting a proposal for 16SSHMT, you are encouraged, but not required, to address this theme. ICOHTEC has also suggested a number of subthemes; see the ICOHTEC call for papers: <file:///E:/00%20ICOHTEC%20Prague%202021/2021-CfP-ICOHTEC-Prague.pdf>.

General information about lodging, transportation, travel grants, and other matters will be posted on the conference website: <http://www.icohtec.org/w-annual-meeting/eindhoven-2020/>

The Symposium of the Social History of Military Technology, a regular part of the ICOHTEC annual meeting since 2005, strives to move beyond the narrow material focus that the history of military technology often assumes among fans, antiquarians, and many historians. As commonly practiced, the history of military technology centers on weaponry, warships, fortifications, or other

physical manifestations of warfare, stressing their making, workings, or usage. Historians have also tended to assume a strictly utilitarian and rational basis for military technological invention and innovation. However necessary they may be, such approaches largely ignore some very important questions. What are the contexts of social values, attitudes, and interests, non-military as well as military, that shape and support (or oppose) these technologies? How do the social order and military technology reciprocally interact? Or, more generally: How do social and cultural environments within the military itself or in the larger society affect military technological change? And the indispensable corollary: How does changing military technology affect other aspects of society and culture? In brief, this symposium will address military technology as both agent and object of social change, taking a very broad view that encompasses not only the production, distribution, use, and replacement of weapons and weapon systems, but also communications, logistics, medicine, and other technologies of military relevance, as well as sciences of military interest.

We seek papers about: (1) representations of weapons as well as weapons themselves, about ideas as well as hardware, about organization as well as materiel; (2) ways in which social class, race, gender, culture, economics, politics, or other extra-military factors have influenced and been influenced by the invention, R&D, diffusion, or use of weapons or other military technologies; (3) the roles that military technologies play in shaping and reshaping the relationships of soldiers to other soldiers; soldiers to military, political, and social institutions; and military institutions to other social institutions, most notably political and economic; and/or (4) historiographical or museological topics that discuss how military technology has been analyzed, interpreted, and understood in other fields, other cultures, and other times. Pre-modern and non-Western topics are particularly welcome.

**All proposals must be submitted in English.** Although papers may be presented in English, French, German, Spanish, or Russian, ICOHTEC does not provide simultaneous translation. Proposals must include a short descriptive title of the paper, an abstract (maximum 300 words), and a short CV (maximum 1 page). **Be sure to include your name and email address, and to specify your present institutional affiliation (or independent status).**

(1) **Abstracts** are strictly limited to 300 words or less. They should include a concise statement of the thesis, a brief discussion of the sources, and a summary of the major conclusions. **Please do not include notes or bibliography.**

(2) Your **CV** must be no longer than 1 page. It should include your educational and professional employment histories, notice of significant publications and/or presentations. You may include other relevant information in the CV, as long as you do not exceed the 1-page limit.

### **Objects Of Understanding: Historical Perspectives On Material Artefacts And Practices In Science Education**

**Europa-Universität Flensburg (Germany), 29 June – 3 July 2020**

We would like to invite the submission of paper and poster abstracts for a five-day conference on the history of objects and practices in science education. Understanding the history of science education is essential if we want to understand the generation, reproduction and circulation of scientific knowledge, practices, practitioners, and objects. While history of science education has moved from the periphery to the focus of history of science in recent decades, the central role of instruments, demonstrations and models in teaching has barely been explored. Particularly with respect to the analysis of scientists' formation in different periods, the role of objects and of

practices in laboratories appears to be crucial. Moreover, with respect to the political and social function that was ascribed to science, the role and purpose of objects in school science education needs a more thorough reflection. In this conference, we want to discuss objects that were explicitly designed for the purpose of science education such as teaching demonstrations and students' experiments, models and collections of specimens. Moreover, we want to address the relationship between teaching and research instruments and collections, and the practices associated with them. We explicitly want to bring together objects and practices from the different contexts and periods of science teaching in schools and technical training institutes, the formation of future scientists at universities, and teaching a general audience about and through science. Following the conference Learning by Doing hosted in 2009 at the University of Regensburg, we invite historians of science as well as scholars from neighboring fields such as material culture studies, history of education and science museums to present their work on the historical development and role of objects that were intended to represent, present and transfer knowledge within the scientific disciplines.

We invite proposals for presentation of individual papers of 20 minutes as well as posters. Please submit an abstract of no more than 250 words to [OoU-conference@uni-flensburg.de](mailto:OoU-conference@uni-flensburg.de). The deadline for submission of abstracts is 6 January 2020, notification about acceptance will be sent by 1 February 2020. Organizers: Peter Heering, Europa-Universität Flensburg, Germany, and Roland Wittje, Indian Institute of Technology Madras, Chennai, India. The conference is sponsored by the Scientific Instrument Commission (SIC), the International History, Philosophy, and Science Teaching Group (IHPST), the International Committee for University Museums and Collections (UMAC) and Universeum, the European Academic Heritage Network.

### **Seventh Annual Conference on the History of Recent Social Science (HISRESS)**

University of Toronto, June 12-13, 2020

This two-day conference of the Society for the History of Recent Social Science (HISRESS; <https://hisress.org>) will bring together researchers working on the history of post-World War II social science. It will provide a forum for the latest research on the cross-disciplinary history of the post-war social sciences, including but not limited to anthropology, economics, psychology, political science, and sociology as well as related fields like area studies, communication studies, history, international relations, law, and linguistics. The conference aims to build upon the recent emergence of work and conversation on cross-disciplinary themes in the postwar history of the social sciences.

Submissions are welcome in such areas including, but not restricted to:

- \* The interchange of social science concepts and figures among the academy and wider intellectual and popular spheres
- \* Comparative institutional histories of departments and programs
- \* Border disputes and boundary work between disciplines as well as academic cultures
- \* Themes and concepts developed in the history and sociology of natural and physical science, reconceptualized for the social science context
- \* Professional and applied training programs and schools, and the quasi-disciplinary fields (like business administration) that typically housed them
- \* The role of social science in post-colonial state-building governance

- \* Social science adaptations to the changing media landscape
- \* The role and prominence of disciplinary memory in a comparative context
- \* Engagements with matters of gender, sexuality, race, religion, nationality, disability and other markers of identity and difference

The two-day conference will be organized as a series of one-hour, single-paper sessions attended by all participants. Ample time will be set aside for intellectual exchange between presenters and attendees, as all participants are expected to read pre-circulated papers in advance.

Proposals should contain no more than 1000 words, indicating the originality of the paper. The deadline for receipt of abstracts is February 7, 2020. Final notification will be given in early March 2020 after proposals have been reviewed. Completed papers will be expected by May 15, 2020.

The organizing committee consists of Jamie Cohen-Cole (George Washington University), Philippe Fontaine (École normale supérieure Paris-Saclay), Jeff Pooley (Muhlenberg College), Mark Solovey (University of Toronto), and Marga Vicedo (University of Toronto).

All proposals and requests for information should be sent to [hisress2020@gmail.com](mailto:hisress2020@gmail.com).

### **Evidence: The Use and Misuse of Data**

June 4-5, 2020, American Philosophical Society

Philadelphia, PA

Inspired by its 2020 exhibition *Dr. Franklin, Citizen Scientist*, the American Philosophical Society Library & Museum is organizing a daylong symposium that explores the nature of evidence. The symposium reflects Benjamin Franklin's many different uses of information and data throughout his life. His work with electricity relied on experimental data, while his work in oceanography relied on observed data as well as the incorporation of ideas borrowed from other observers. As a newspaper publisher and essayist, he produced and often reproduced news and other important information. Through his almanacs, he shared a wide range of knowledge with the public. Later in life, his service on a French commission investigating mesmerism deployed the scientific method to test the reliability of evidence itself. Given Franklin's myriad uses of and approaches to evidence, the APS Library & Museum invites innovative proposals from scholars who wish to explore the past, present, and future use of evidence and data.

Potential topics include (but are not limited to):

- ≈ The various ways evidence has been interpreted differently over time and the ways it has been applied and misapplied to shape policy and decisions;
- ≈ The past, present, and future methods used to collect evidence and present findings, and the opportunities and potential problems associated with such methods;
- ≈ The presence and misuse of bad data, erroneous evidence, and misinformation, and the ways such material have affected the production of knowledge and threaten it today;
- ≈ The role of bias during data collection and its interpretation by scholars;
- ≈ The opportunities and perils presented when evidence produces unexpected results.

Applicants should submit a title and a 250-word proposal along with a C.V. by **December 13, 2019** via Interfolio: <https://apply.interfolio.com/69616>. The symposium will be held on June 4-5, 2020 in Philadelphia. Decisions will be announced in February 2020. All presenters will receive travel subsidies and hotel accommodations. Accepted papers will be due a month before the conference and pre-circulated to registered attendees. Papers should be no longer than 15 double-spaced

pages. Presenters may also have the opportunity to publish revised papers in the APS's Proceedings, one of the longest running scholarly journals in America. For more information, visit <https://www.amphilsoc.org/>, or contact Adrianna Link, Head of Scholarly Programs, at [alink@amphilsoc.org](mailto:alink@amphilsoc.org).

### **2020 History of Economics Society (HES) Conference**

Utrecht University Hall, Netherlands, 18-21 June 2020

The annual HES Conference will take place at the Utrecht University Hall in Utrecht, The Netherlands, 18-21 of June 2020. Papers dealing with any aspect of the history of economics are welcome, including work related to any period or any school of economic thought. Also welcome are papers that situate economics in wider intellectual and cultural contexts or relate it to other disciplines. Although we welcome proposals for individual papers, proposals for complete sessions are especially encouraged. To submit a paper or session proposal, go to the conference web page <https://historyofeconomics.org/hes2020/>, where there is a link to a form for making submissions. Those proposing papers will be asked to submit an abstract of about 250 words, while those proposing sessions will be asked for an abstract of about 750 words that lists all participants, titles and very brief descriptions of the papers to be included. The HES website for conference registration (<https://historyofeconomics.org/hes2020/>) will open on January 2, and will provide information on several hotels where blocks of reduced rate rooms have been reserved. We encourage scholars from neighboring disciplines to participate; please see the past conference programs posted on the HES website. Inquiries regarding session proposals are most welcome, and should be addressed to Marcel Boumans at [m.j.boumans@uu.nl](mailto:m.j.boumans@uu.nl). All conference sessions will be an hour and a half. So usually a session consists of three paper presentations, but you can of course also choose another format. The DEADLINE for submissions is **February 1 2020**. The early registration deadline for the conference is February 28. The HES provides support for several Warren J. and Sylvia J. Samuels Young Scholars to present papers at the conference, in the form of free registration, banquet and reception tickets, and a year's membership in the society. Some of the Young Scholars awardees will also receive a grant of \$500 to cover travel and other costs. A Young Scholar must be a current PhD candidate, or have been awarded a PhD in 2017 or later. Those interested in having their paper considered for the Young Scholars program will be able to indicate their interest when they submit their paper proposal through the conference website, and will be contacted subsequently with more details about the program. For all young scholars applying to HES there will be a pre-conference workshop organized.

Petroleum History Institute 2020 Annual Symposium  
The World of West Coast Petroleum April 2-4, 2020



**CALL FOR PAPERS**  
ABSTRACT DEADLINE: March 1, 2020

**PETROLEUM HISTORY INSTITUTE  
2020 ANNUAL SYMPOSIUM  
AND FIELD TRIP**



REGISTRATION AND EVENING RECEPTION Thursday, April 2, 2020

PRESENTATIONS – ORAL AND POSTER -- Friday, April 3, 2020 Proceedings to be published in the 2020 volume of Oil-Industry History

FIELD TRIP -- Saturday, April 4, 2020

HEADQUARTERS HOTEL – Best Western/Pepper Tree Inn, Santa Barbara, California  
<https://groups.guestreservations.com/eh/37s4c-66h> or 800-338-0030 For Group Rate Mention “Petroleum History Institute”

ABSTRACTS BEING ACCEPTED Please send abstracts to: Dr. William Brice - [wbrice@pitt.edu](mailto:wbrice@pitt.edu) or call Marilyn Black – 814-677-3152 ext. 105; [mblack@oilregion.org](mailto:mblack@oilregion.org)

REGISTRATION DETAILS TO FOLLOW

**Technikwenden in Vergangenheit und Zukunft /Technological Changes in History and Future**  
Jahrestagung des VDI Ausschusses Technikgeschichte in Kooperation mit dem Fachgebiet Technikgeschichte, TU Berlin.

Termin: 27./28. Februar 2020

Ort: Technische Universität Berlin

Call for Papers, Deadline: 10. Nov. 2019

Please contact Heike Weber, TU Berlin, [h.weber@tu-berlin.de](mailto:h.weber@tu-berlin.de)

**Canadian Society for the History of Medicine (CSHM), May 30 - June 1, 2020. Western University,  
London, Ontario**

The 2020 meeting of the Canadian Society for the History of Medicine will take place May 30-June 1, 2020 at Western University, in London, Ontario, situated on the traditional lands of the



Anishinaabek, Haudenosaunee, Lūnaapéewak and Attawandaron (Neutral) people, on lands connected with the London Township and Sombra Treaties of 1796 and with the Dish with One Spoon Covenant Wampum. In conjunction with the 2020 Congress of the Humanities and Social Sciences, the Programme Committee calls for papers that address the theme of this year's Congress: "Bridging Divides: Confronting Colonialism and Anti-Black Racism". Proposals on topics unrelated to the Congress theme are also welcome. Scholars are invited to present research on the broadly-defined histories of medicine, healing, health, and disease. Please submit an abstract of less than 350 words and one-page CV for consideration by November 29, 2019 by e-mail to [cshm2020@uwo.ca](mailto:cshm2020@uwo.ca). The Programme Committee also encourages proposals for organised panels of three (3) related papers; in this case, please submit a panel proposal of less than 350 words in addition to an abstract and one-page CV from each presenter. The Committee will notify applicants of its decision by January 31, 2020. Those who accept an invitation to present at the meeting agree to provide French and English versions of the accepted abstract for inclusion in the bilingual Programme Book.

## XI. JOBS, POSTDOCTORAL POSITIONS, RESEARCH FELLOWSHIPS, AND GRADUATE SCHOOL OPPORTUNITIES

### **Belgium**

- ❖ [Postdoctoral researcher in Languages and Cultures](#)  
Ghent University, Department of Languages and Cultures
- ❖ [Postdoc scientific assistant in Languages and Cultures](#)  
Ghent University, Department of Languages and Cultures
- ❖ [Postdoctoral researcher, Future expectations in the late Middle Ages and early modern period](#)  
University of Antwerp, Department of History of the Faculty of Arts and Philosophy

### **Denmark**

- ❖ [Tenure-track assistant professorship in transdisciplinary art studies](#)  
University of Copenhagen, Department of Arts and Cultural Studies, Faculty of Humanities
- ❖ [Postdoc in Privacy and Data Studies](#)  
University of Copenhagen, Department of Communication, Faculty of Humanities
- ❖ [2 PhD scholarships in transdisciplinary art studies](#)  
University of Copenhagen, Department of Arts and Cultural Studies, Faculty of Humanities

### **Finland**

- ❖ [University Lecturer in New Testament studies](#)  
University of Helsinki, Faculty of Theology

### **Ireland**

- ❖ [Tutor in Primary and Post Primary Education](#)  
Hibernia College School of Education - Professional Master of Education (PME)
- ❖ [Tutor in Primary and Post Primary Education](#)  
Hibernia College School of Education - Professional Master of Education (PME)

### **Singapore**

- ❖ [Assistant Professor in Data Analytics](#)  
National University of Singapore

- ❖ [Assistant Professor in Open Specialisation](#)  
National University of Singapore
- ❖ [Assistant Professor in Digital Media](#)  
National University of Singapore
- ❖ [Assistant Professor in Computational Communication](#)  
National University of Singapore
- United Arab Emirates**
- ❖ [Assistant Professor in Department of Languages and Literature](#)  
United Arab Emirates University, Department of Languages and Literature
- United States**
- ❖ [Lecturers in Various Fields of History](#)  
University of California Berkeley, Department of History
- ❖ [Lecturer Pool in Premodern and Modern Korean Literature and Culture-East Asian Languages & Cultures](#)  
University of California Berkeley, College of Letters and Sciences
- ❖ [Assistant Professor in Native American History](#)  
University of California Davis, Department of Native American Studies
- ❖ [Lecturer Pool in Premodern and Modern Chinese Literature & Culture](#)  
University of California Berkeley, College of Letters and Sciences
- ❖ [Assistant or Associate Professor of Iranian Studies](#)  
University of California Berkeley, College of Letters and Sciences
- ❖ [Assistant Professor or Associate Professor in Chicana/Latina Literature and Culture](#)  
University of California Berkeley, College of Letters and Sciences
- ❖ [Lecturer in Department of Communication](#)  
University of California Davis, Department of History
- ❖ [Lecturer Pool in Department of African American Studies](#)  
University of California Berkeley, Department of African American Studies
- ❖ [Assistant/Associate/Full Professor of Modern Italian Literature in Department of Italian Studies](#)  
University of California Berkeley, College of Letters and Sciences
- ❖ [Lecturer Pool in French Language and Culture](#)  
University of California Berkeley, College of Letters and Sciences
- ❖ [Lecturer Pool in Digital Humanities](#)  
University of California Berkeley, College of Letters and Sciences
- ❖ [Lecturer Pool in History of Art Department](#)  
University of California Berkeley, College of Letters and Sciences
- ❖ [Assistant Professor in 20th/21st century Mexican, Mexican American and/or Central American Literary and/or Cultural Studies](#)  
University of California Davis, Department of History
- ❖ [Temporary Teaching Opportunities in History](#)  
University of California Davis, Department of History

#### **Open Level Faculty Position- Environmental Ethics**

The Environmental Studies Program at the University of California, Santa Barbara invites applications for a tenured or tenure-track faculty position at the level of Assistant, Associate, or Full

Professor, with an anticipated start date of July 1, 2020. The Program is looking for individuals with particular emphasis in the area of Environmental Ethics.

The Program seeks candidates with backgrounds in philosophy or a related field in the social sciences or humanities. For this position, we define “ethics” broadly to include any of the three traditional areas of inquiry in this field —meta-, normative, or applied ethics. The Program is particularly interested in scholars who have both theoretical and applied interests, and whose work crosses disciplinary, methodological, cultural, or geographic boundaries. Possible focus areas include climate change, conservation, food and agriculture, risk and vulnerability, the role of science in society, decision-making, social inequality, law, and politics.

Established in 1970, the Environmental Studies Program at UC Santa Barbara is one of the oldest and largest programs of its kind, with more than 1,000 current majors and over 7,000 alumni. The program has a longstanding commitment to interdisciplinary research and teaching, and a balance among the biophysical sciences, social sciences, humanities, and applied professions. UC Santa Barbara is a Hispanic Serving Institution, and more than 40 percent of our undergraduates are first-generation college students. For more information, please see <http://www.es.ucsb.edu/>

Responsibilities of faculty members generally include a research program of the highest quality, teaching at undergraduate and/or graduate levels, recruitment, supervision, and mentorship of graduate students, and participation in university service and professional activities. At a minimum, all applicants must have completed all requirements for a PhD (or equivalent) except the dissertation at the time of application. A PhD in Environmental Ethics or a related field is required by anticipated appointment start date. Additionally, Associate/Full rank candidates should have research experience in academia or industry after receipt of PhD. A demonstrated record of excellence in research, and a record of (or potential for) excellent teaching are desired. We are especially interested in candidates who show a potential for cross-campus collaboration, and who can contribute to the diversity of our university community. Successful candidates will have a record of collaborative research and will be able to participate in an interdisciplinary environment within the Environmental Studies Program and Division. The University is especially interested in candidates who can contribute to the diversity and excellence of the academic community through research, teaching and service as appropriate to the position.

Applications should be submitted electronically, and must include:

- ▷ Cover letter
- ▷ Curriculum vitae
- ▷ Statement of research
- ▷ Statement of teaching
- ▷ Two recent publications, draft manuscripts, or dissertation/book chapters
- ▷ Applicants at the Assistant rank will need to arrange for 3 references to submit letters of recommendation on their behalf via UC Recruit
- ▷ Applicants at the Associate/Full rank will need to submit the names and contact information for 3 references.

Applications received by **November 15, 2019** will be given priority consideration, but the position will remain open until filled. To apply please visit <https://recruit.ap.ucsb.edu/apply/JPF01567>

## The Global Priorities Institute (GPI) at the University of Oxford

### Four-year postdoc positions

The Global Priorities Institute (GPI) at the University of Oxford - part of the Faculty of Philosophy - is currently advertising four-year postdoc positions (Postdoctoral and Senior Research Fellows in Philosophy). The central focus of GPI is what we call 'global priorities research', research which revolves around the question "What should we do with a given unit of resources if our aim is to do the most good?" More information and example research questions can be found in GPI's research agenda.

For current graduate students, postdocs at GPI are a great way to launch an academic career. Team-based and individual research on global priorities topics is combined with substantial freedom to pursue one's own unrelated projects (e.g. working on publications related to a recent PhD dissertation), there is plenty of funding for infrastructure and travel, and the Institute takes support for career development very seriously. GPI is as yet too young to have an established placement record, but we confidently expect GPI postdocs to go on to tenure-track positions in the very best research universities. More generally, GPI is a vibrant and supportive research environment, with plenty of opportunities for informal discussion as well as multiple more structured research events each week.

**Applications close on 7 November** (midday UK time), and more details on the posts can be found on this website. We particularly encourage applications from women, black and ethnic minority candidates, as these groups are underrepresented in philosophy in general and at GPI in particular. If you are interested in global priorities research or GPI in general, but these posts are not right for, you can also have a look at our opportunities page for more information. There, you can also fill out an expression of interest to get in touch.

Please contact [gpi-office@philosophy.ox.ac.uk](mailto:gpi-office@philosophy.ox.ac.uk) if you have any questions or would like to explore further – we look forward to hearing from you.

## Master's programme in Philosophy of Science, Technology and Society

### University of Twente/Universiteit Twente

The two-year international Master's programme in Philosophy of Science, Technology and Society is for anyone who is interested in philosophy and the role of technology in a broader social context. The PSTS programme is designed for students with technical, philosophical and social science backgrounds. PSTS is characterized by its empirical orientation. Rather than focusing only on philosophical tradition or aiming to understand technology in general, we analyse specific technologies and their impact on society.

Questions you will explore in this Master's programme include:

- α How are information and communication technologies affecting our privacy?
- α Can we anticipate the future implications of nanotechnology for society?
- α Are there ethical limits to the genetic modification of animals and human beings?
- α How do new technologies change our behaviour and our perceptions of the world?

Find details at: <https://www.utwente.nl/en/education/master/programmes/philosophy-science-technology-society/#focus-and-disciplines>

## Willard McCarty Fellowship CALL FOR FELLOWSHIP 2019-2020

The Willard McCarty Fellowship was set up in 2018 by the Department of Digital Humanities at King's College London (<https://www.kcl.ac.uk/artshums/depts/ddh/index.aspx>) in honour of Professor Willard McCarty's (<http://www.mccarty.org.uk/>) ceaseless contribution to the advances and growth of the field of Digital Humanities and the Department. The Fellowship is intended to support outstanding early career scholars whose work interrogates the value of a human-machine

dialogue for greater understanding of the human mind, condition, culture, and society. It seeks to foster intellectual collaboration across borders and disciplines as well as between academia and industry. Candidates are expected to have a strong academic presence and/or significant engagement with the intellectual life of society as a whole. We offer Fellows the opportunity to exchange experiences with colleagues and students in the dynamic environment of the largest academic digital humanities department in the world.

### **Access to Fellowship**

Access to the Willard McCarty Fellowship is given to interdisciplinary-minded academic and non-academic researchers who must have a PhD either awarded or in hand; or equivalent experience. The route to the scheme is to apply as outlined in the Section 'How and When to Apply?'. Candidates will be selected based on the evaluation made by the committee formed from internal and external experts.

The Fellowship must be undertaken at the Department of Digital Humanities for a period from one to two weeks.

Grants of up to £2,500 to successful candidates will cover the following:

- √ Round trip standard class fares
- √ Accommodation and subsistence

We can provide advice, but appointees must make their own travel and living arrangements. They will need to seek additional funding elsewhere to cover any expenses that exceed the grant.

### **The Role of Fellows**

Fellows will be affiliated with the interdisciplinary programme and international staff of the Department, and provided with office space. Fellows will be welcome to attend classes and seminars, to work with the staff of the Department, meet affiliated partners, such as staff of King's Digital Lab, and access Strand campus and all facilities of the Maughan Library. During their stay, holders of the Fellowship will be required to give one lecture to staff of the Department. In addition, they may give one seminar to graduate and postgraduate students. The Department will appoint Mentors during the period of their stay to advise Fellows on writing and publishing, so that if they wish, they may submit a revised version of their lecture for publication in a suitable high-impact journal.

### **How and When to Apply?**

Applications for the WM Fellowship 2019-20 open on Monday 28<sup>th</sup> October 2019, and close on Tuesday 7<sup>th</sup> January 2020.

To be considered for the Fellowship, please submit the following materials:

- × Cover Letter (up to 500 words) indicating reason for interest in this appointment
- × Curriculum Vitae (up to 2 pages, with emphasis on the last ten years)
- × Statement of research interests (up to 1,000 words), outlining the topics and content of the lecture and seminar the Fellow will give during the period of the fellowship
- × Two letters of recommendation

For the 2019-20 Fellowship competition, please submit all materials in one email to both Paul Spence ([paul.spence@kcl.ac.uk](mailto:paul.spence@kcl.ac.uk)) and Gabriele Salciute Civiliene ([gabriele.salciute-civiliene@kcl.ac.uk](mailto:gabriele.salciute-civiliene@kcl.ac.uk)) by January 7, 2020. Please put 'WM Fellowship' in the subject area. Submissions that are incomplete or sent later than the deadline will not be considered. The successful candidate(s) will be notified of the results in early February 2020. The Fellowship will have to take place between March and end of May 2020.

## **Eligibility**

Academic and post-doctoral staff already at King's College London are not eligible for this scheme. The scheme is open to applicants without regard to nationality, race, religious beliefs or gender. Applicants must be fluent in English.

If an applicant needs a visa for entry and stay in the UK, it is his or her responsibility to arrange one before arrival.

## **Studying in Switzerland**

*Studying in Switzerland* is a platform that aims to provide all relevant information about conducting your studies in Switzerland. We have the most comprehensive information about Swiss universities and scholarships, and we keep up to date about living costs in Switzerland. Find complete information and details on *Studying in Switzerland* educational offer at <https://studyinginswitzerland.com/>. Clara Huber, Career Counselor, [clara.huber@studyinginswitzerland.com](mailto:clara.huber@studyinginswitzerland.com)

## **Visiting Scholar Program - Environmental Humanities The Sydney Environment Institute**

The Environmental Humanities is a space for experimental, interdisciplinary, and engaged scholarship. At its core, the field is an effort to bring the insights and approaches of the humanities into conversation around some of the most pressing challenges of our day, from climate change and mass extinction, to urbanisation and extraction. It is a field grounded in the insistence that these 'environmental' challenges are also inherently social and cultural, and as such they require understandings and responses that take the complexity of human life as seriously as they do the complexity of ecological, geophysical, and climatic systems. In this way, work in the environmental humanities has sought to foreground human diversity—modes of meaning-making, of valuing, of exposure and vulnerability—to explore how we might move forward in ways that are not only sustainable, but also just, inclusive, and genuinely life-enhancing.

Since its foundation in 2013 the Sydney Environment Institute has played a leading role in fostering the environmental humanities in Australia and beyond. We have hosted key conferences and workshops, been partners in the launch of important book series and journals, and we serve as the hub of the Australia-Pacific observatory within the international [Humanities for the Environment](#) initiative.

At present we are home to a variety of collaborative environmental humanities projects in areas that range from Multispecies Justice and Unsettling Ecological Poetics, to Extinction Studies and Everyday Militarisms. In the coming years we aim to deepen and strengthen the conversations and collaborations at the core of the environmental humanities. This means working across disciplines, across universities, but also beyond the university entirely. At the heart of this effort is a desire to cultivate an environmental humanities that is deeply rooted in the insights and approaches of Indigenous, feminist, anti-racist, and multispecies scholarship, an approach that takes seriously both the immense challenges and the incredible possibilities of our current moment.

Applications are now open to scholars working within the Environmental Humanities. <http://sydney.edu.au/environment-institute/news/sei-news-applications-2020-visiting-scholars-environmental-humanities/>. The 2020 program will enable two scholars to spend time with us in Sydney collaborating, sharing ideas and facilitating conversation in this broad field of research. Visitors will have the opportunity to present a seminar or workshop for postgraduate students or

early career researchers, and we are open to other ideas for creative and novel collaboration. SEI will cover a return airfare, accommodation and per diem for a period of two weeks, as well as providing a desk, library access and research support for the visitor's entire stay. While our funding only covers two weeks in Sydney, we hope that some visitors will be able to connect this funding to a sabbatical or period of study leave to stay on for a longer period. For more information on funding, visitor activities, eligibility criteria and the application process, please see a detailed description of the program [here](#). Prospective applicants are welcomed to contact Associate Professor Thom van Dooren ([thom.van.dooren@sydney.edu.au](mailto:thom.van.dooren@sydney.edu.au)) with any further questions. Applications will close on **Friday January 17, 2020**.

## X. Join ICOHTEC

Please share this form with a colleague who is not yet a member or ask your library to subscribe



### **Form for annual membership renewals / registration of new members**

**Annual membership includes subscription to ICOHTEC's refereed annual journal ICON, access to all back issues of ICON in electronic form via the ICOHTEC website, a monthly Newsletter, and special registration rates at the annual ICOHTEC symposium.**

*I wish to renew my membership / to become a new member in ICOHTEC. (Tick below the appropriate description/rate):*

- An individual. Rate: (40 \$ or 30 € or equivalent) per year*
- A student. Rate: (40 \$ or 30 € or equivalent for two years)*
- An institution. Rate: (100 \$ or 75 € or equivalent) per year*
- A library. Rate: (Europe: 36 €, Overseas 39 € or 52 \$) per year*

*Tick the years of membership to be paid:*  **2017**  **2018**  **2019**  **2020**

*I submit the total amount:* \_\_\_\_\_ euro (or USD)

*Your first name and surname:* \_\_\_\_\_

*Email:* \_\_\_\_\_

*Postal address:* \_\_\_\_\_

*Country:* \_\_\_\_\_

*Tick the method of your payment:*

- Through international money transfer: Make international money transfer to:

“ICOHTEC“ at Commerzbank Bochum (Husemannplatz 3-4, D-44787 Bochum, Germany):

IBAN: DE44 4304 0036 0390 2590 00; BIC: COBADEFFXXX (members in Germany take

Commerzbank Bochum BLZ 43040036, Nr. 390259000).

- Through a cheque. Send the check with the appropriate sum made out to “ICOHTEC” and send to:  
Dr. Lars Bluma, Otmarstrasse 5, D-45131 Essen, Germany.

**After filling the form, please scan and send by email to Timo Myllyntaus, ICOHTEC Treasurer at timmyl@utu.fi or, send a hardcopy by regular mail to Timo Myllyntaus, Turku School of Economics, Rehtorinpellonkatu 3 Room 313, 20 500 Turku, Finland. Your filled form will facilitate sending ICONs and allocating access privileges.**